

版本 REV.	日期 DATE	ECN NO.	变更内容 DESCRIPTION	制图 DRAWN

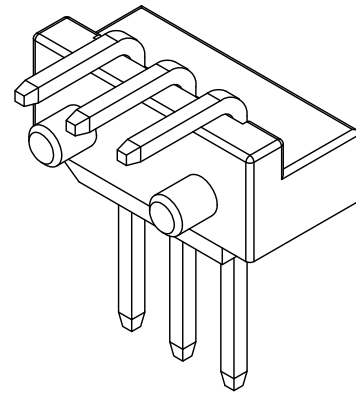

SPECIFICATIONS

- Current Rating: 2A AC, DC
- Voltage Rating: 250V AC, DC
- Temperatuer Range: -25°C~+85°C
- Contact Resistance: 30mΩ Max
- Insulation Resistance: 1000MΩ Min
- Withstanding Voltang: 800V AC/minute
- Material:  
Wafer PA66, UL94V-0  
PIN Brass Tin-plated

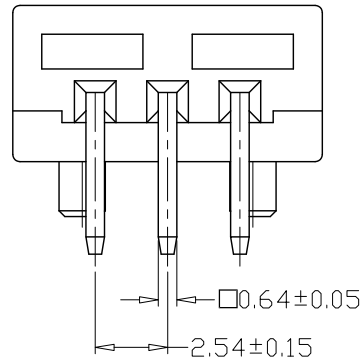
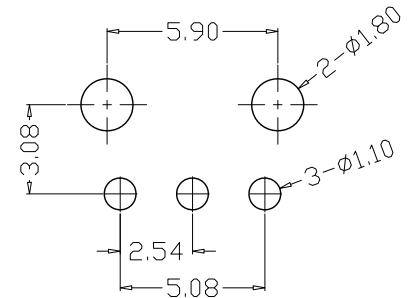
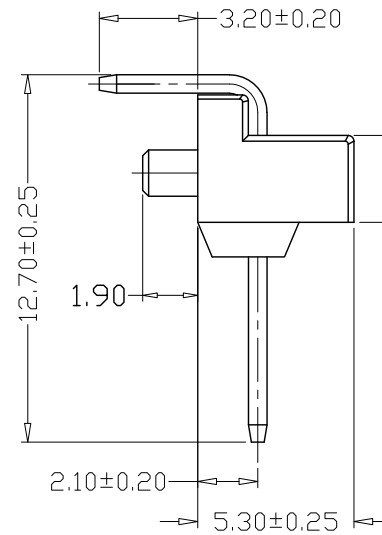
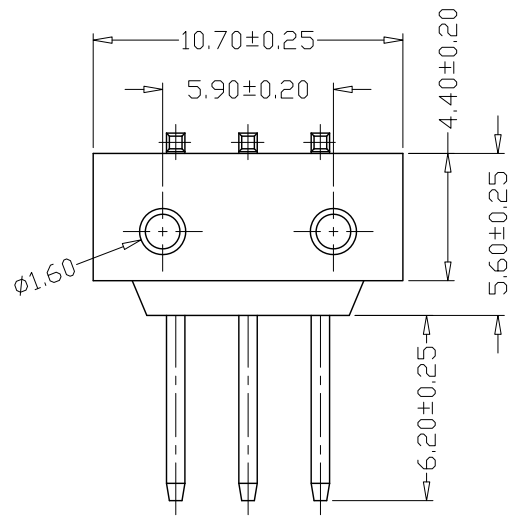

PCB LAYOUT

GENREL TOLERANCE		制图 Mapping	张迎春 2023、01、28	料号 PART NO.	C25404-3AW	版本 REV.	A
X±0.25	X°±2°	审核 Audit	钱岳生 2023、01、28	品名 TITLE	25415-弯针 WAFER DIP TYPE	页次 SHEET	1/1
.X±0.25	.X°±1°	核准 Approved	张名 2023、01、29	客户料号 CUTM. NO.		乐清市宏一电子有限公司 YueQing HongYi Electronics Co., Ltd	
.XX±0.15	.XX°±0.5°	单位 Units	MM	比例 SCALE	1:1		
.XXX±0.10	.XXX°±0.5°						